

RoHS  
COMPLIANT

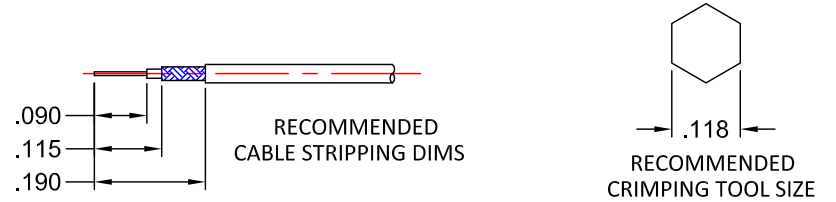
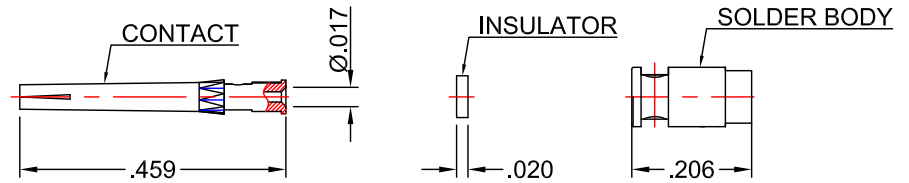
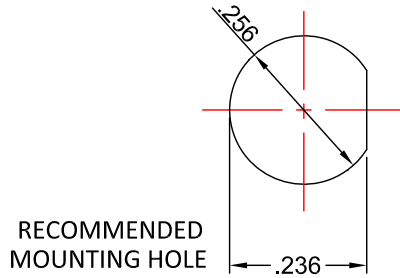
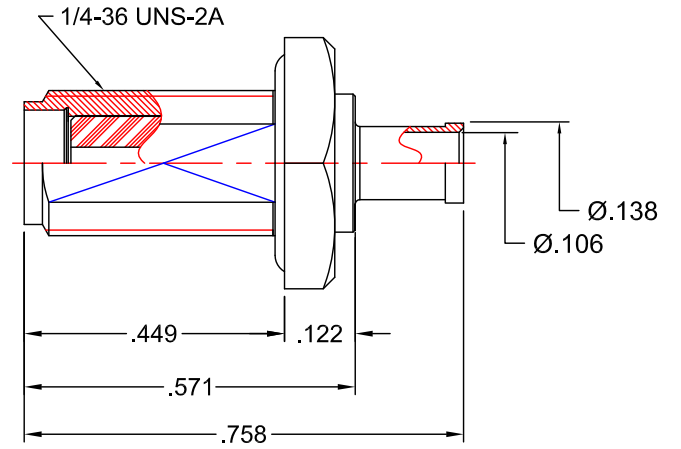
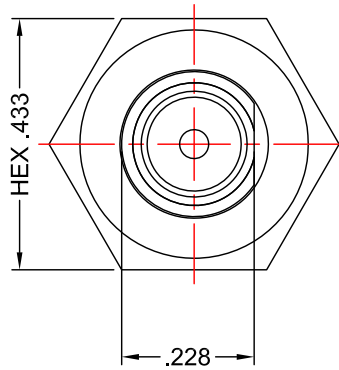
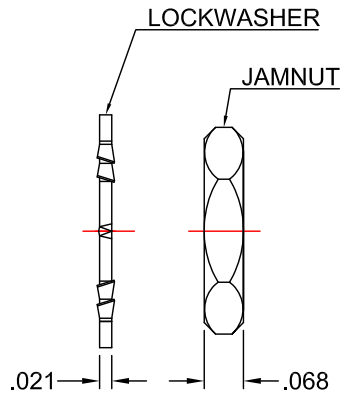

**NOTES:**

INTERFACE CONFORMS TO MIL-PRF-39012 AND MIL-STD-348 SMA SERIES

**ELECTRICAL:**

NOMINAL IMPEDANCE: 50Ω  
FREQUENCY RANGE: DC TO 12 GHz

**MATERIALS:**

INSULATOR: TEFLON PER ASTM-D-1710  
CONTACT: BERYLLIUM COPPER PER ASTM-B-196  
BODIES, JAM-NUT, WASHER, & CRIMP SLEEVE: 360 ALLOY BRASS 1/2 HARD PER ASTM-B-16  
GASKET & O'RING: SILCONE RUBBER PER ZZ-R-765

**FINISHES:**

CONTACT: GOLD PLATE PER MIL-DTL-45204  
BODY, JAM-NUT, WASHER, & SOLDER BODY: GOLD PLATE PER MIL-DTL-45204

**PROPRIETARY NOTICE**  
THIS DRAWING AND DESIGNS AND IDEAS EMBEDDED IN THE DEVICE TO WHICH IT RELATES AND THE METHOD OF PRODUCING THE DEVICE SHALL NOT BE EMPLOYED COPIED OR DISCLOSED TO ANYONE IN ANY MANNER WITHOUT THE WRITTEN CONSENT OF AN EZ FORM COMPANY OFFICIAL

APPD.	T.D.
DATE 4/11/17	4/11/17
BY J.N.	
DATE 4/11/17	
DESCRIPTION	INITIAL RELEASE
REV.	—

<b>UNLESS OTHERWISE SPECIFIED:</b>			
DIMENSIONS ARE IN INCHES:		SCALE 3:1	
TOLERANCES: NONE			
MATERIAL: SEE NOTES			
FINISH: SEE NOTES			
DRAWN	DATE	CHECKED	DATE
J.N.	4/11/17	T.D.	4/11/17
APPROVED	DATE	SHEET 1 OF 1	
A.T.	4/11/17		

	<b>EZ Form Cable Corporation</b> 285 Welton Street Hamden, CT 06517 WWW.ezform.com	
	TITLE SMA BULKHEAD JACK WITH "O" RING CRIMP FOR RG-178	
CODE IDENT. <b>A</b> 9W826	705569-001SMA	REV. -